

2 ROOF PLAN  
1" = 50'-0"

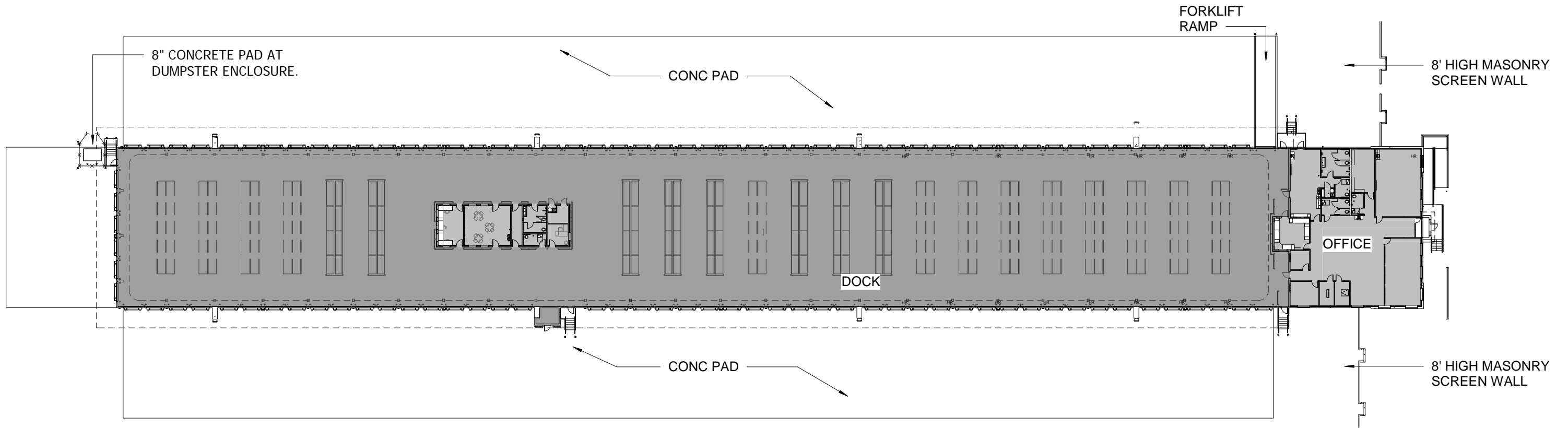

1 FLOOR PLAN  
1" = 50'-0"



ODFL MESA, AZ  
OVERALL FLOOR PLAN

11 x 17 = 1" = 50'-0"

03/19/19



49 Music Square W - Suite 600  
Nashville, Tennessee 37203  
615.296.9146  
www.themdglic.com



③ BLDG ELEVATION - SOUTH  
1" = 20'-0"

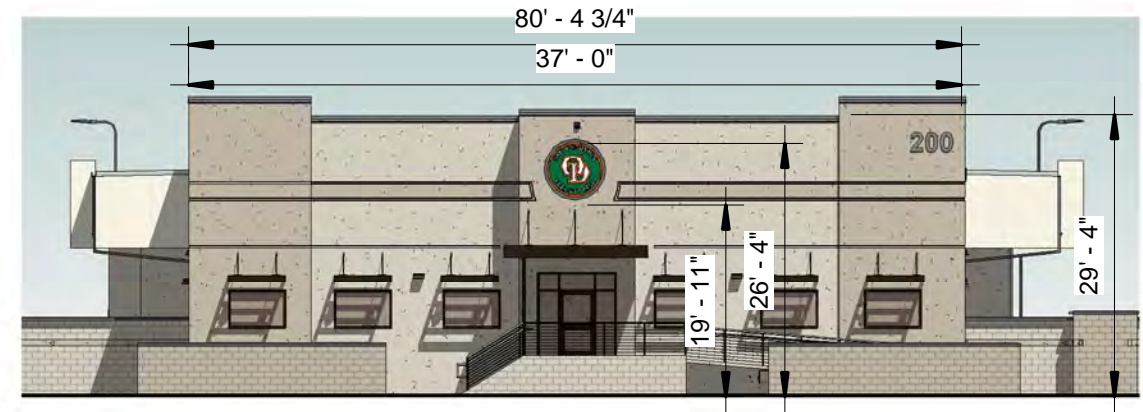

② BLDG ELEVATION - NORTH  
1" = 20'-0"



① VIEW LOOKING WEST



ODFL MESA, AZ  
EXTERIOR ELEVATIONS

11 x 17 = 1" = 20'-0"

03/04/19



49 Music Square W - Suite 600  
Nashville, Tennessee 37203  
615.296.9146  
www.themdglic.com



④ WEST ELEVATION  
1" = 50'-0"



③ EAST ELEVATION  
1" = 50'-0"

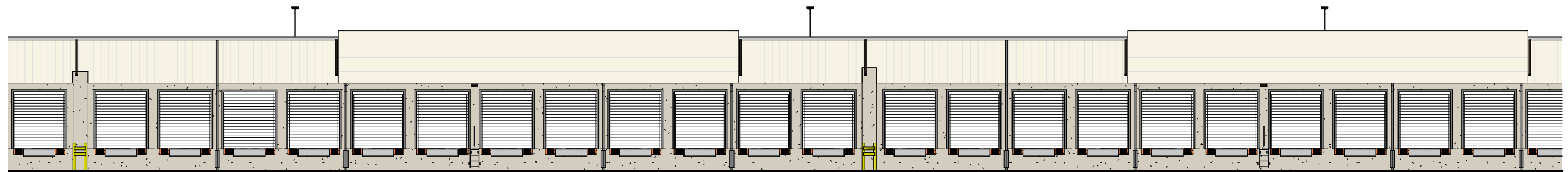

② TYPICAL SIDE ELEVATION  
1" = 20'-0"



① VIEW FROM NORTH EAST



ODFL MESA, AZ  
EXTERIOR ELEVATIONS

11 x 17 = As indicated

03/04/19



49 Music Square W - Suite 600  
Nashville, Tennessee 37203  
615.296.9146  
www.themdgllc.com

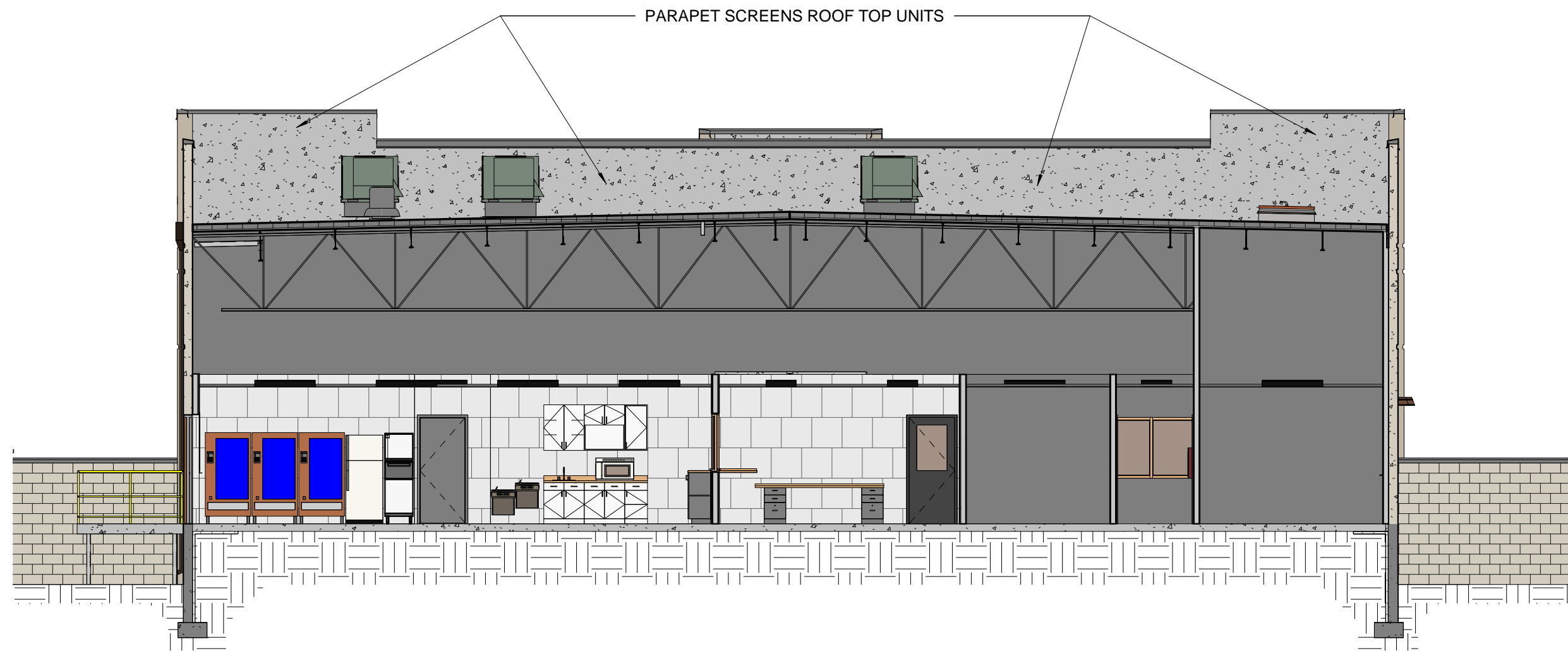

1 OFFICE BUILDING SECTION  
 1/8" = 1'-0"



ODFL MESA, AZ  
 BUILDING SECTION

11 x 17 = 1/8" = 1'-0"

03/19/19



49 Music Square W - Suite 600  
 Nashville, Tennessee 37203  
 615.296.9146  
[www.themdglc.com](http://www.themdglc.com)

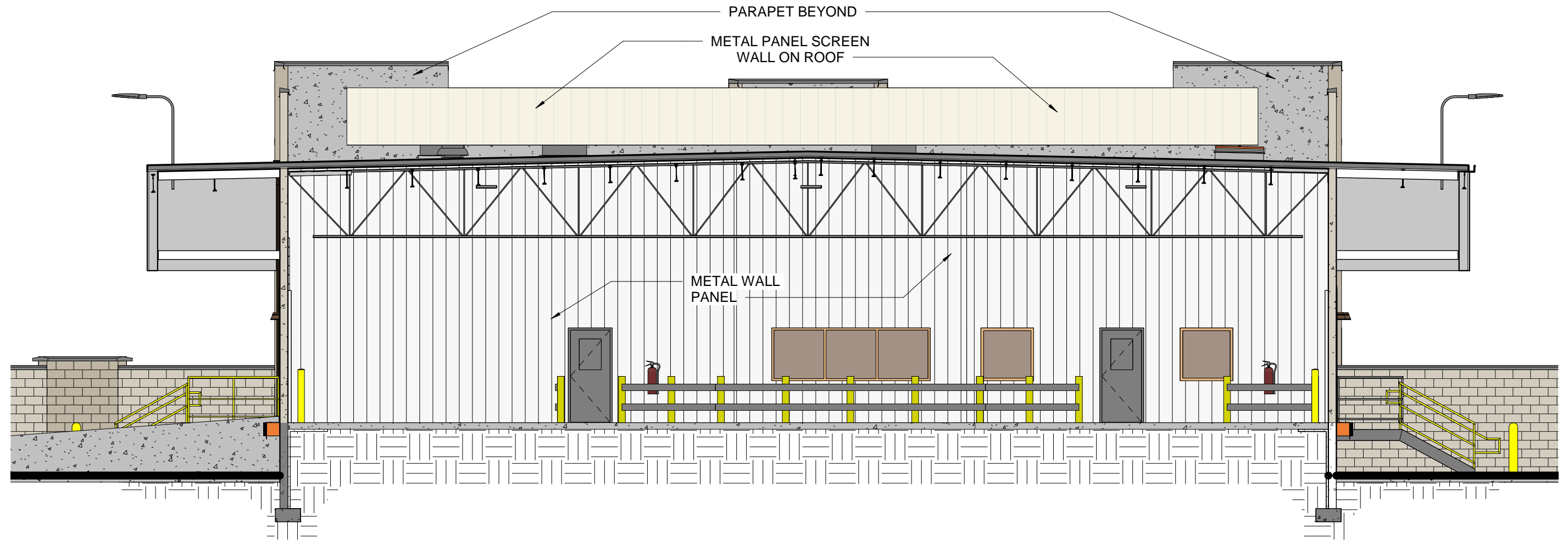

1 DOCK SECTION  
 1/8" = 1'-0"



ODFL MESA, AZ  
 BUILDING SECTION

11 x 17 = 1/8" = 1'-0"

03/19/19



49 Music Square W - Suite 600  
 Nashville, Tennessee 37203  
 615.296.9146  
[www.themdgllc.com](http://www.themdgllc.com)

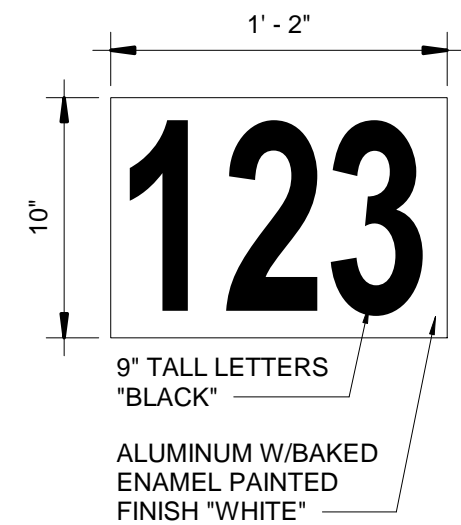

EXTERIOR SIGN ABOVE EACH DOCK DOOR

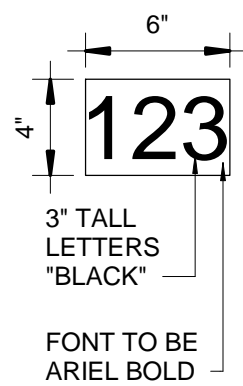

INTERIOR JAMB SIGN AT DOCK DOORS

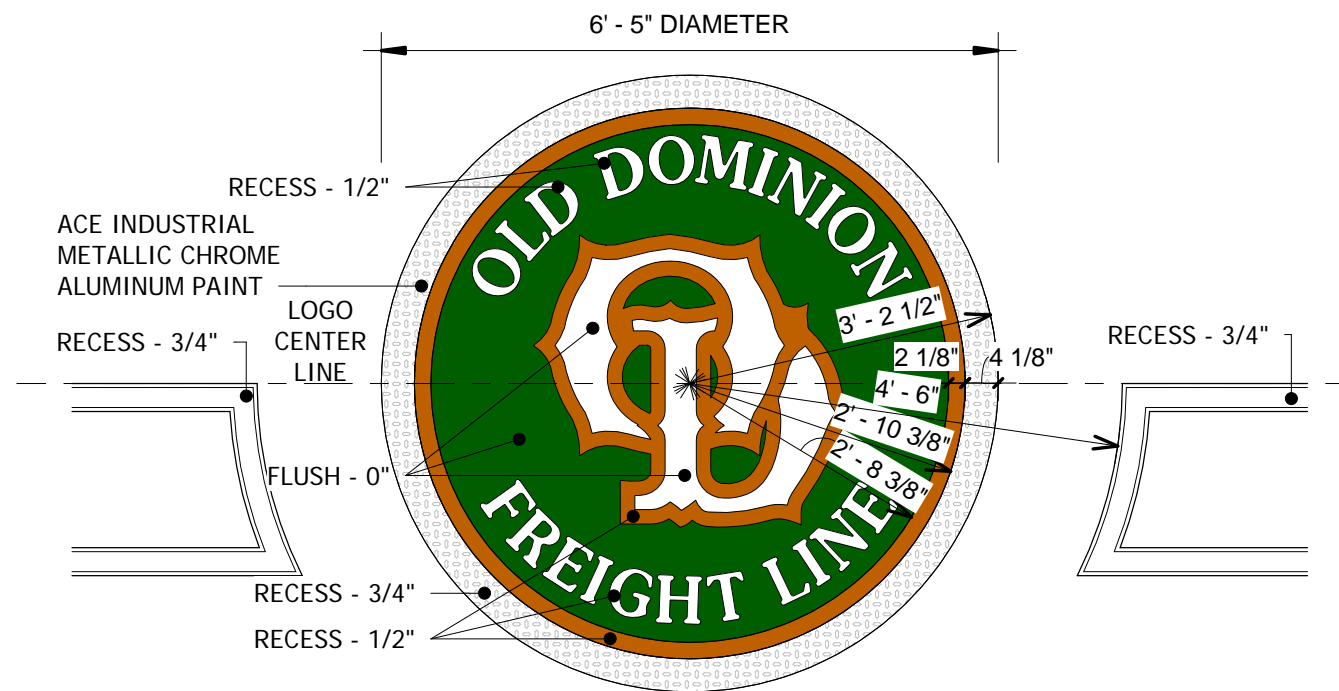

RECESSED LOGO IN CONCRETE PANEL

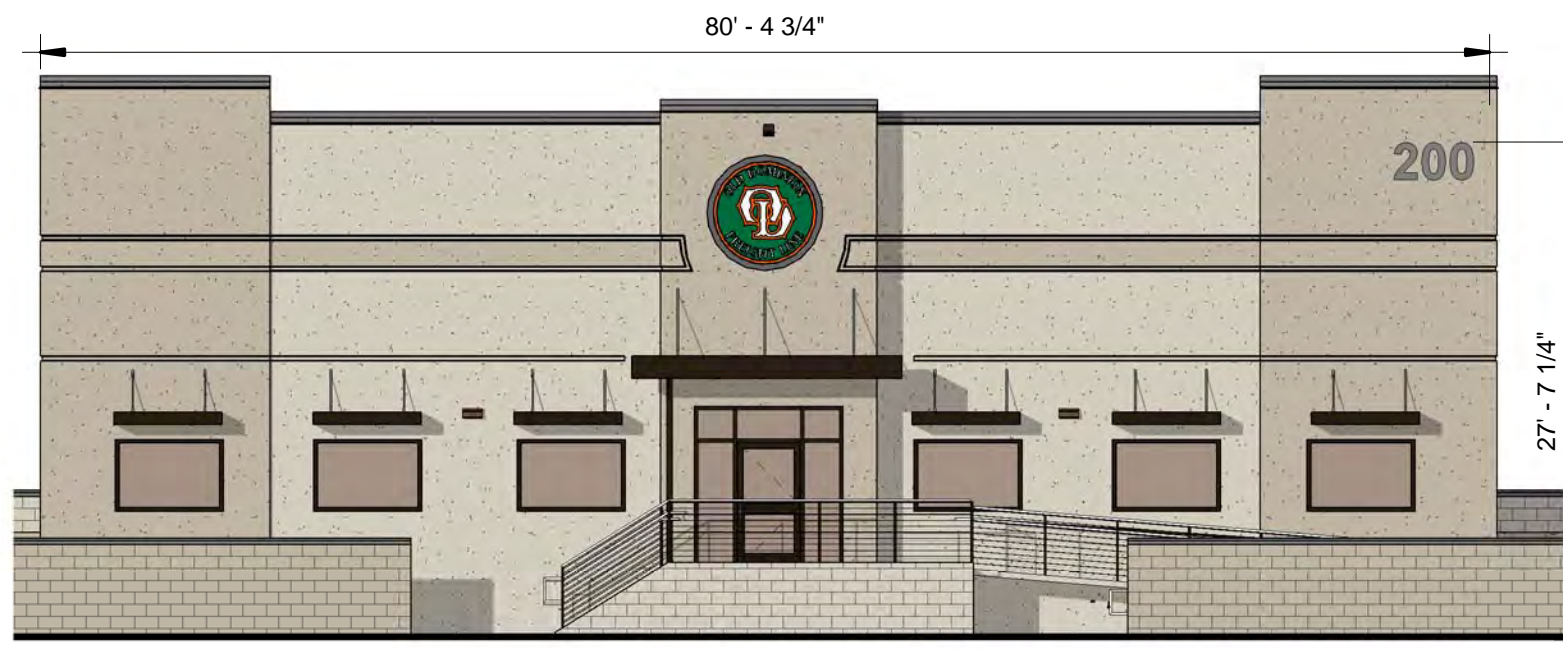

FRONT ELEVATION

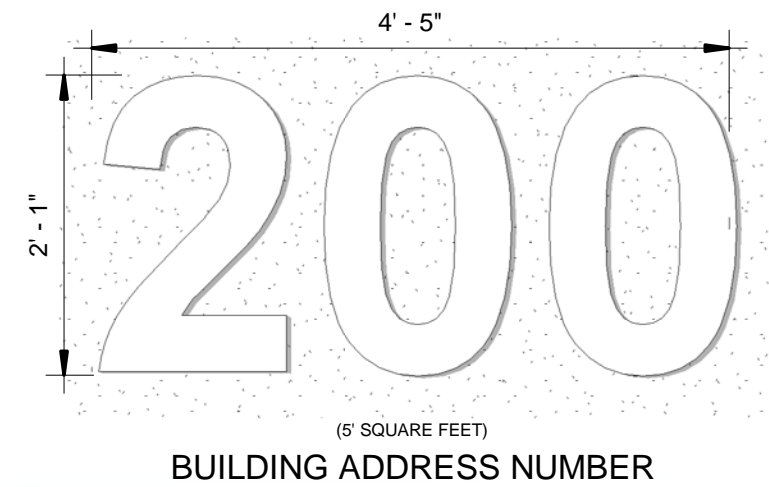

GROUND SIGN PHOTO

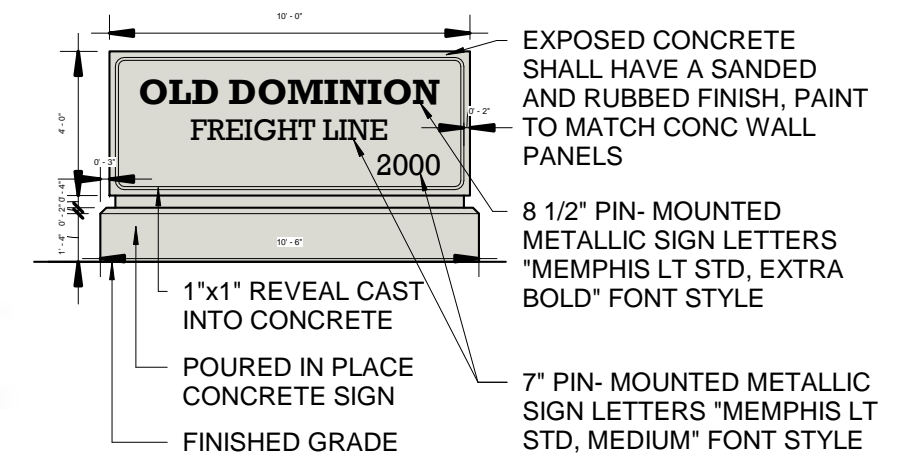

ILLUMINATED GROUND SIGN



ODFL MESA, AZ  
EXTERIOR SIGNAGE SUBMITTAL

11 x 17 = As indicated

03/19/19



49 Music Square W - Suite 600  
Nashville, Tennessee 37203  
615.296.9146  
www.themdglic.com

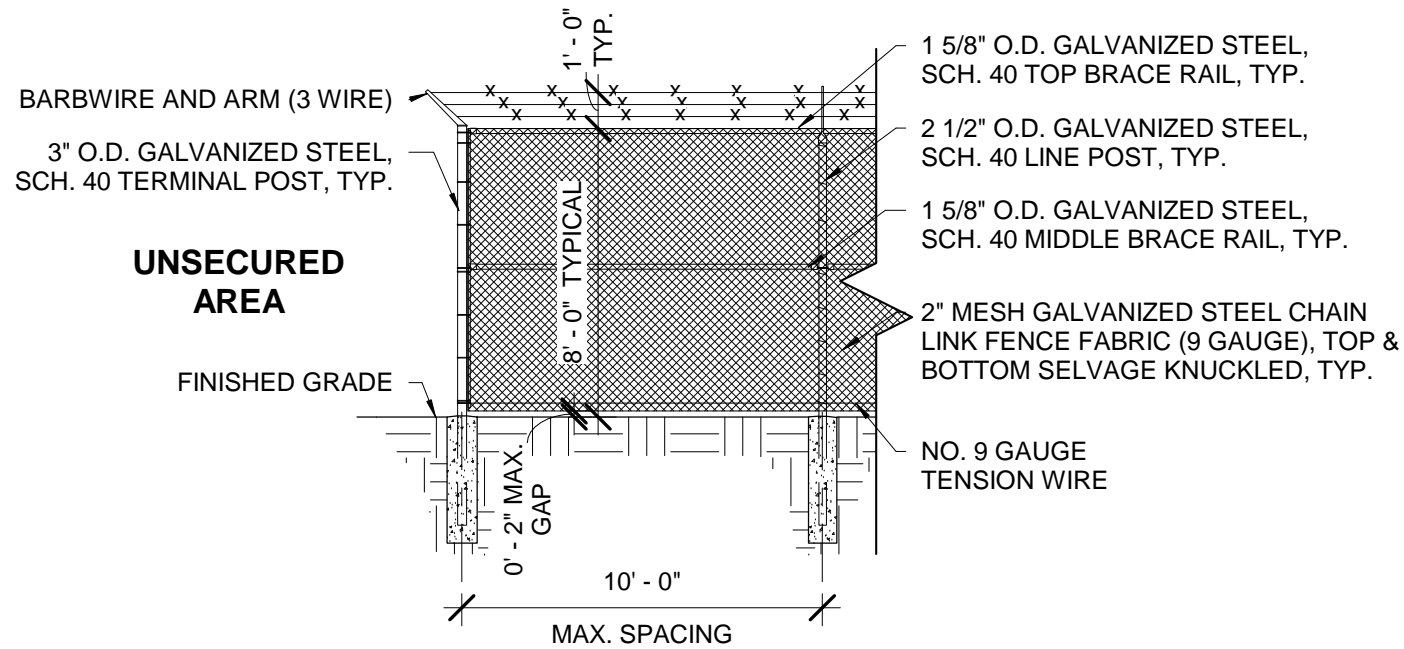

**4 REAR AND SIDE YARD FENCE ELEVATION**  
3/16" = 1'-0"

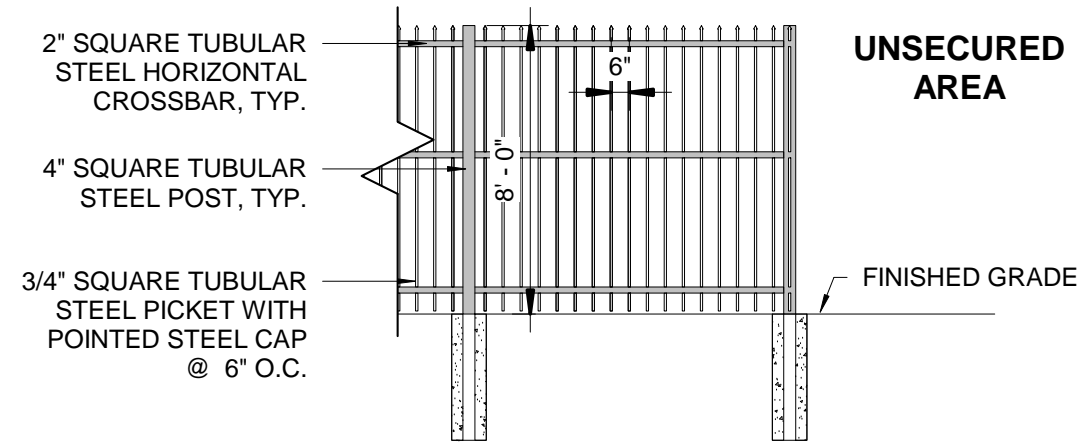

**3 TYP EMPLOYEE PARKING FENCE SECTION**  
3/16" = 1'-0"

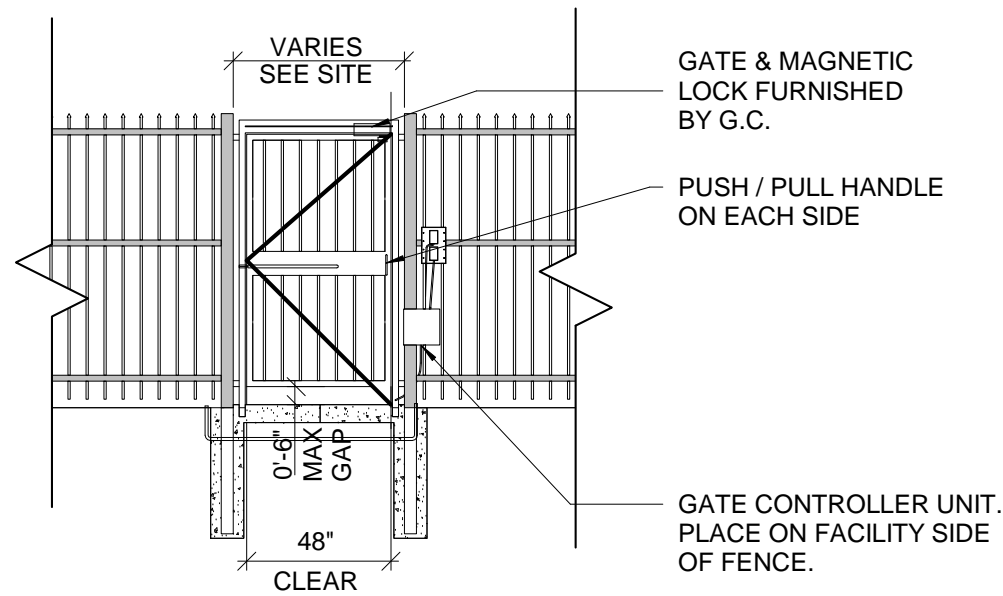

**2 MAN GATE AT EMPLOYEE PARKING FENCE**  
3/16" = 1'-0"

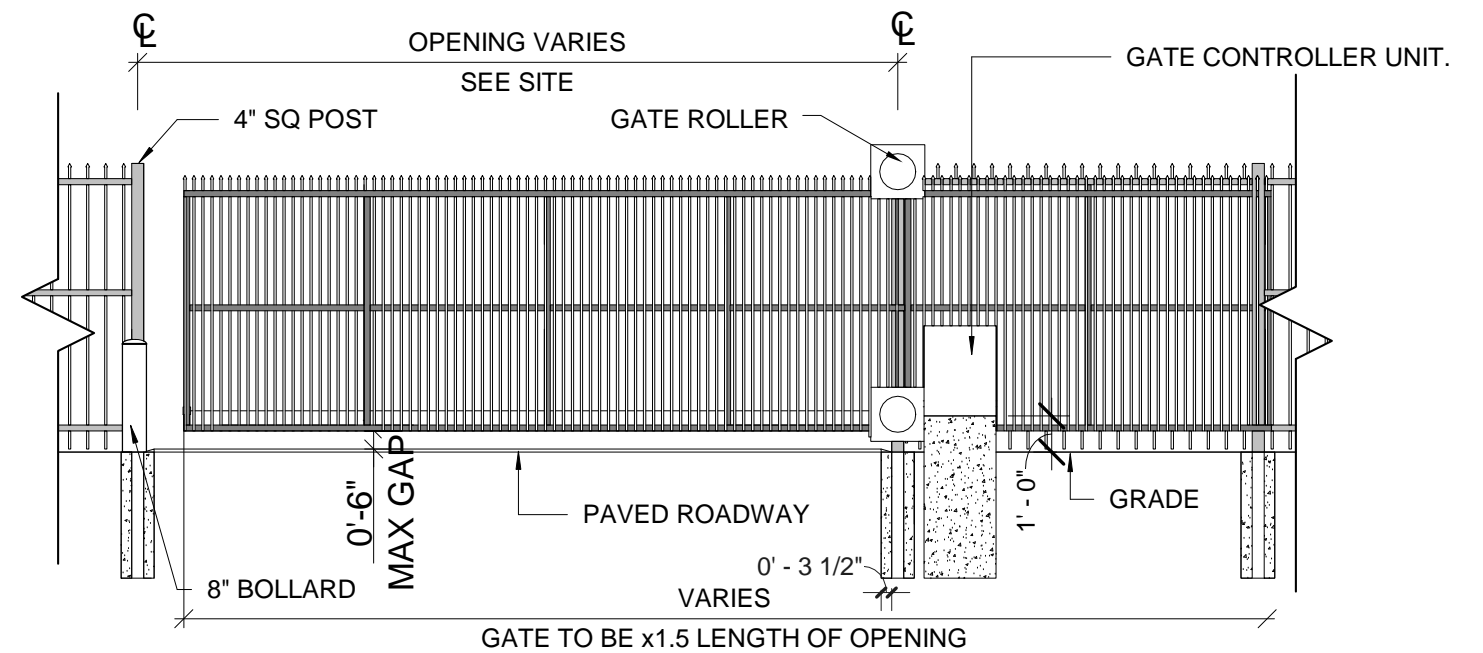

**1 VEHICLE GATE**  
3/16" = 1'-0"



ODFL MESA, AZ  
TUBULAR FENCE DETAILS

11 x 17 = 3/16" = 1'-0"

03/19/19



49 Music Square W - Suite 600  
Nashville, Tennessee 37203  
615.296.9146  
www.themdgllc.com



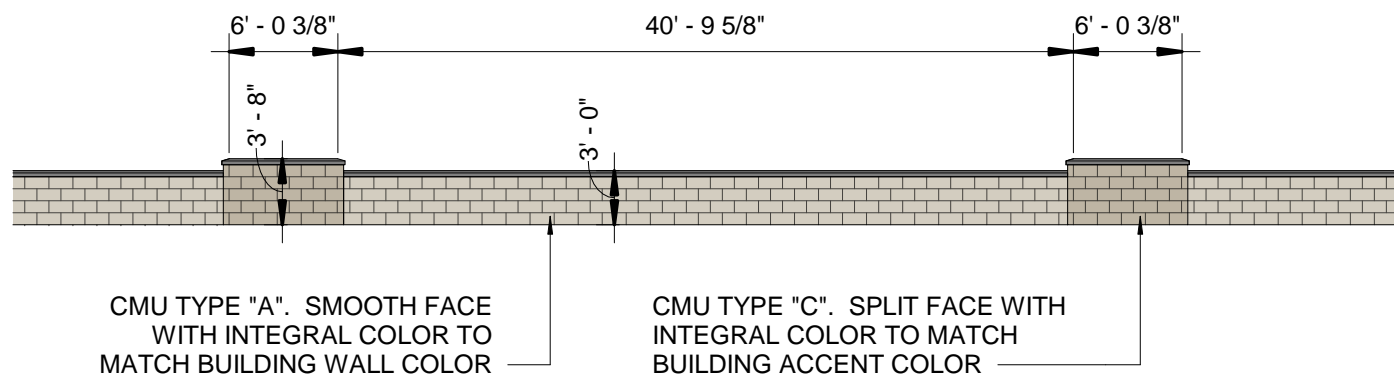

**4 HEADLIGHT SCREEN WALL - ELEVATION**  
 3/32" = 1'-0"

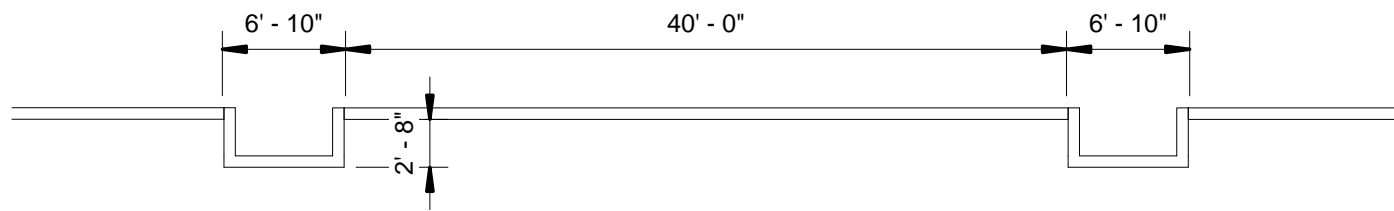

**3 HEADLIGHT SCREEN WALL - PLAN**  
 3/32" = 1'-0"

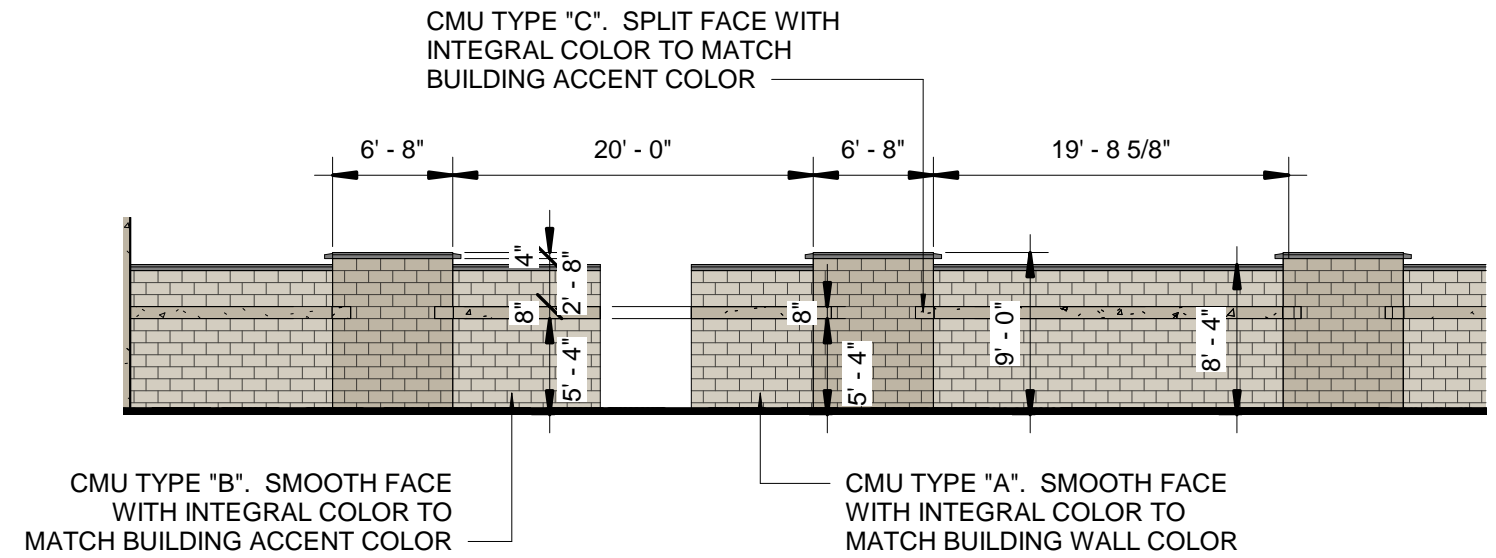

**2 STORAGE AREA SCREEN WALL - ELEVATION**  
 3/32" = 1'-0"

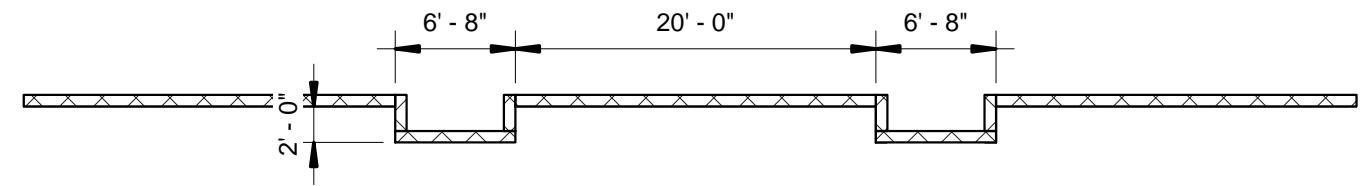

**1 STORAGE AREA SCREEN WALL - PLAN**  
 3/32" = 1'-0"



ODFL MESA, AZ  
 SCREEN WALL DETAILS

11 x 17 = 3/32" = 1'-0"

03/19/19



49 Music Square W - Suite 600  
 Nashville, Tennessee 37203  
 615.296.9146  
[www.themdgllc.com](http://www.themdgllc.com)

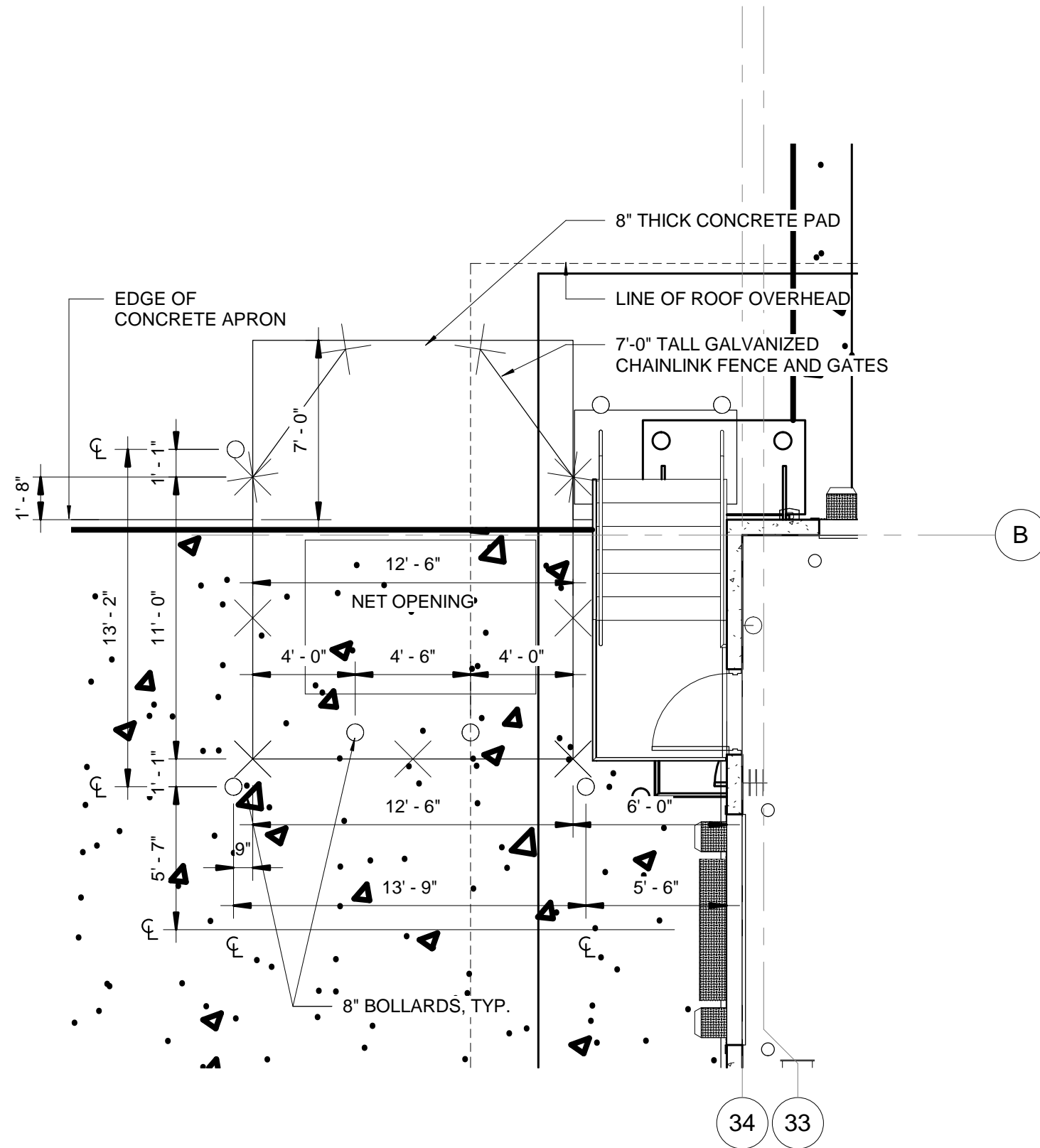

ODFL MESA, AZ  
 ENLARGED DUMPSTER ENCLOSURE

11 x 17 = 3/16" = 1'-0"

03/19/19



**SITE DATA:**

APN: 304-63-006N  
 FULL PARCEL AREA: 12,662,017± SF (290.67± AC)  
 PROJECT PARCEL AREA: 811,446± SF (18.62± AC) (AFTER LOT SPLIT)  
 EXISTING ZONING: G-I  
 EXISTING USE: AGRICULTURAL  
 PROPOSED ZONING: G-I  
 ADJACENT ZONING: G-I  
 MAXIMUM HEIGHT: 50.0'  
 PROPOSED BLDG HT: 29.0'  
 BUILDING SF: 51,880 SF  
 LOT COVERAGE: 51,880 / 811,446 = 6.39%

SETBACKS: REQUIRED BLDG PROV. LS PROV.  
 FRONT 20' (BUILDING & LANDSCAPE) 345.97' 54.06'  
 REAR 0' (ADJACENT TO PAD (G-I)) 394.81' 12.00'  
 SIDE 0' (ADJACENT TO PAD (G-I)) 280.20' 76.00'

PARKING REQUIRED:  
 CITY OF MESA:  
 INDUSTRIAL 1 SPACE PER 600 SF: 51,880/600= 87 SPACES  
 MAX PARKING ALLOWED = 125% OF REQUIRED = 87\*1.25= 109 SPACES

PARKING PROVIDED:  
 5 ADA SPACES  
 1 VAN SPACE  
 98 STANDARD SPACES  
 104 TOTAL SPACES

**LEGEND**

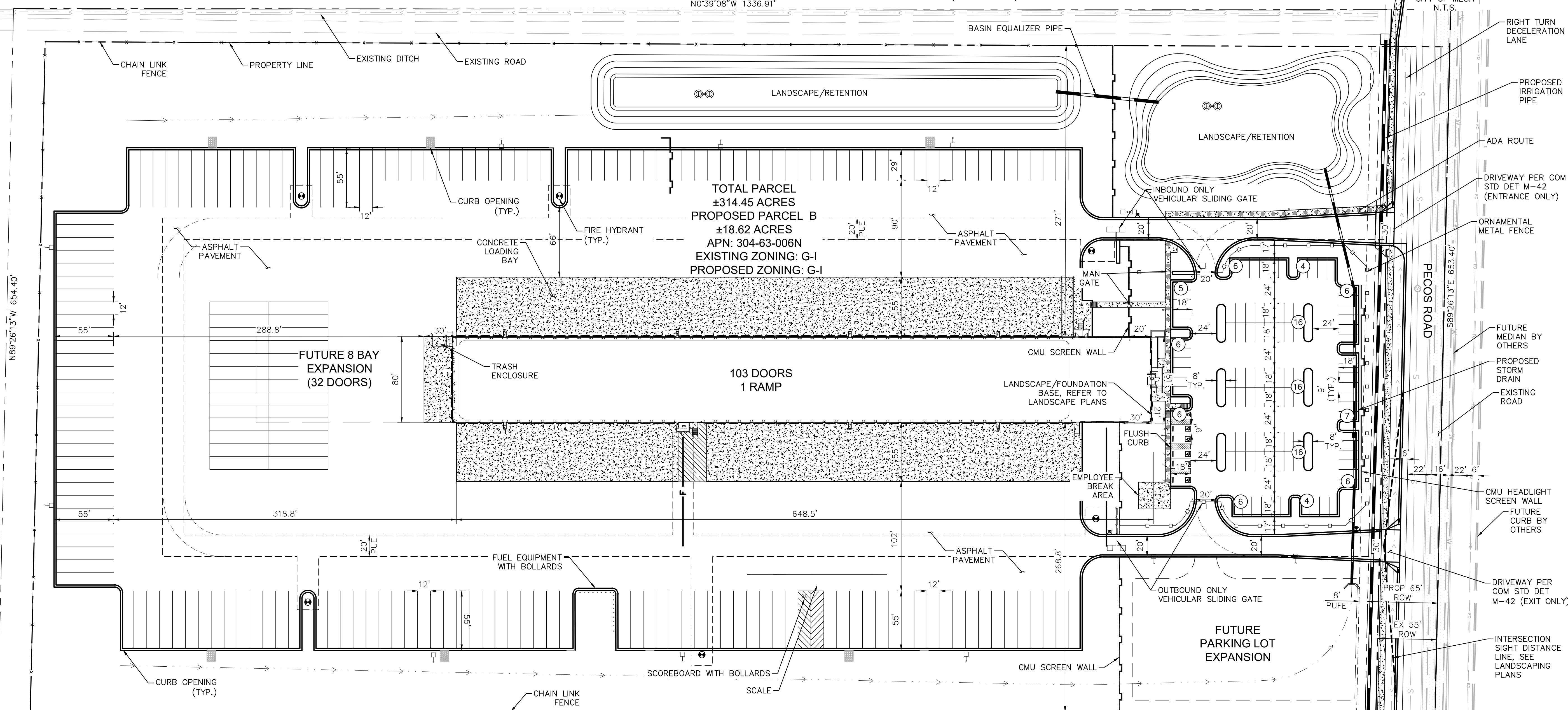
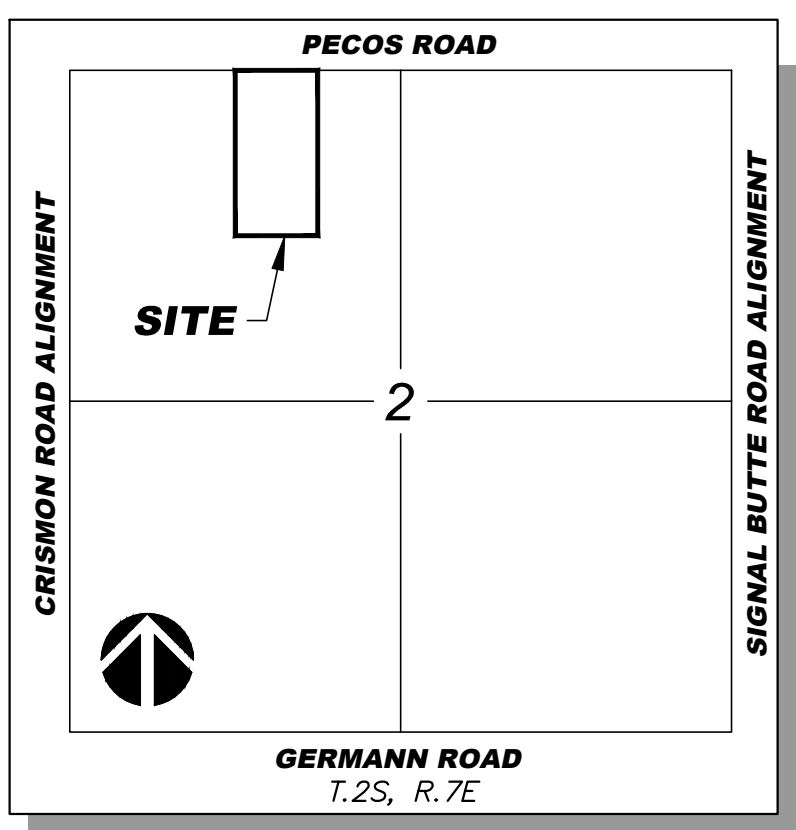
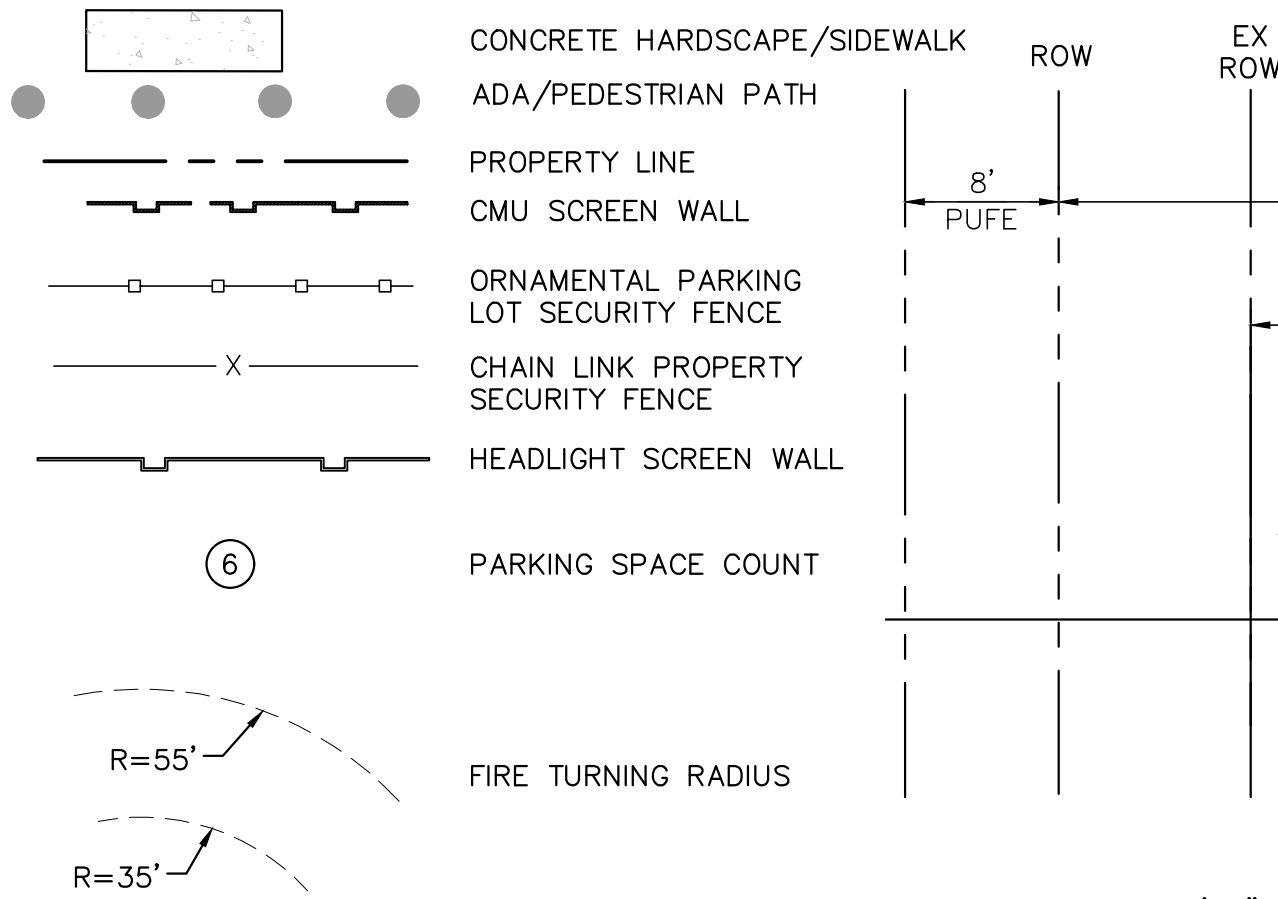

**Kimley»Horn** ©2019  
 1001 West Southern Ave, Suite 131  
 Mesa, Arizona 85210 (480)207-2666

ODFL MESA  
 SITE PLAN  
 SEC PECOS RD & CRIMSON RD  
 MESA, ARIZONA

PROJECT No. 291303001  
 SCALE (H): 1"=50'  
 SCALE (V): NONE  
 DRAWN BY: PR  
 DESIGN BY: PR  
 CHECK BY: JB  
 DATE: 03/04/19

**PRELIMINARY**  
 FOR REVIEW ONLY  
 NOT FOR CONSTRUCTION  
  
 ENGINEER J. BURM  
 PE NO. 52081 DATE 03/19  
 291303001SP.dwg  
 C01  
 01 OF 04 SHEETS

K:\E\291303001 - 00\_Prelim\CAD\DWG\291303001.dwg User: jhills Date: 03/04/19 8:08am zchh.hill  
 THIS DOCUMENT, TOGETHER WITH THE CONCEPTS AND DESIGN PRESENTED HEREIN, IS AN INSTRUMENT OF SERVICE, IS INTENDED ONLY FOR THE SPECIFIC PURPOSE AND CLIENT FOR WHICH IT WAS PREPARED. REUSE OR REPRODUCTION OF THIS DOCUMENT WITHOUT THE WRITTEN PERMISSION OF KIMLEY-HORN AND ASSOCIATES, INC. IS STRICTLY PROHIBITED.

**ARCHITECT**  
 DAVID MOLLENKOPF ARCHITECT  
 49 MUSIC SQUARE W, SUITE 600  
 NASHVILLE, TN 37203  
 TEL. NO. (615) 296-9146  
 CONTACT: ANDY DONNELLY AIA

**CIVIL ENGINEER**  
 KIMLEY-HORN AND ASSOCIATES, INC.  
 1001 W. SOUTHERN AVE, SUITE 131  
 MESA, AZ 85210  
 TEL. NO. (480) 207-2666  
 CONTACT: JASON BURM, PE

**LAND SURVEYOR**  
 SURVEY INNOVATION GROUP, INC.  
 22425 N. 16TH ST, SUITE 1  
 PHOENIX, ARIZONA 85024  
 PH: (480) 922-0780  
 CONTACT: JASON SEGNARI R.L.S.

**DEVELOPER**  
 OLD DOMINION FREIGHT LINE, INC.  
 500 OLD DOMINION WAY  
 THOMASVILLE, NC 27360  
 TEL. NO. (366) 822-1291  
 CONTACT: J. CRAIG KISER

**LANDSCAPE ARCHITECT**  
 KIMLEY-HORN AND ASSOCIATES, INC.  
 1001 W. SOUTHERN AVE, SUITE 131  
 MESA, AZ 85210  
 TEL. NO. (602) 906-1103  
 FAX NO. (602) 944-7423  
 CONTACT: ANDREW VALESTIN, PLA

**NOTE:**  
 ALL DIMENSIONS ARE TO FACE OF CURB UNLESS OTHERWISE NOTED.

**BASIS OF BEARING**  
 THE NORTH LINE OF THE NORTHWEST QUARTER OF SECTION 2, TOWNSHIP 2 SOUTH, RANGE 7 EAST, SAID LINE BEARS NORTH 89 DEGREES 26 MINUTES 13 SECONDS WEST.

**BENCHMARK**  
 FOUND BRASS TAG IN HANDHOLE AT THE NORTHWEST CORNER OF BRIDGE AT THE INTERSECTION OF SOSSAMAN ROAD AND GERMAN STREET.  
 ELEVATION = 1356.84 (NAD88, CITY OF MESA)

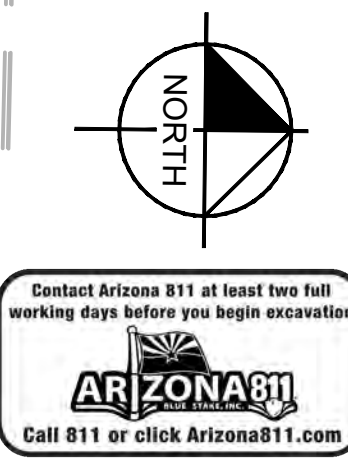
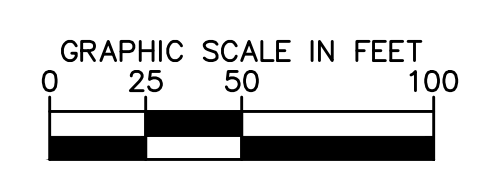

Contact Arizona 811 at least two full working days before you begin excavation  
  
 Call 811 or click Arizona811.com







